

Sec A-A

Heat treated to 1650-1750 N/mm<sup>2</sup>

$\sqrt{R_z 25}$  ( $\sqrt{R_z 6.3}$ )

Machine: 5-130,140		Factory: Extrusion		Sheet: 1
Weight: 752 Kg		Part Name: Stem		1 Sheets:
79	Date	Name	Reference Drawing No:	
drawn	3.3	K. Ebrahimi	5011020-06202	
Checked		H. Baganadeh	Drawing No:	Work QTY. Part NO.
Approved		A. Alinaghjourn	P5000-0800	1 1
			Material: 1.2367	Min. Stock: 1
			SHAHID BAHONAR COPPER INDUSTRIES CO.	

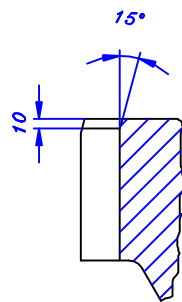
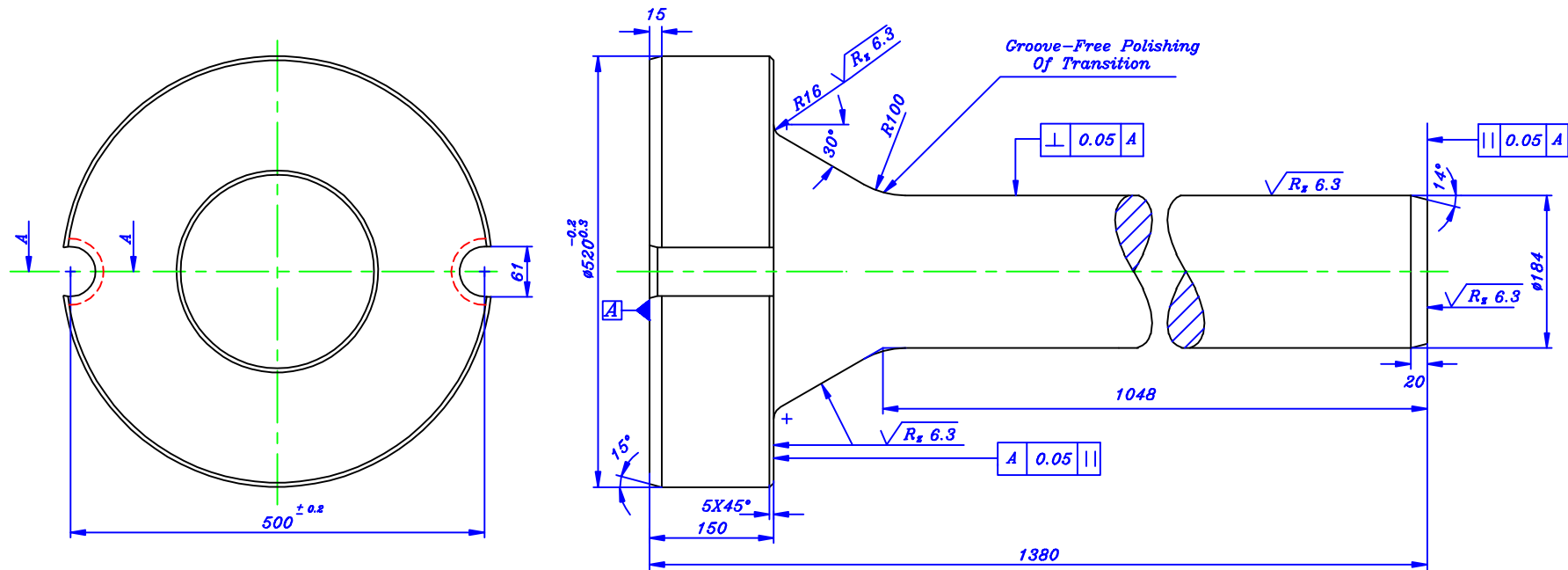

Sec A-A

Heat treated to 1650-1750N/mm<sup>2</sup>

$\sqrt{R_z 25}$  ( $\sqrt{R_z 6.3}$ )

Machine: 5-130,140		Factory: Extrusion		Sheet: 1
Weight: 620kg		Part Name: Stem		1 Sheets:
79	Date	Name	Reference Drawing No:	Scale: 1:5
drawn	3.3	K. Ebrahimi	5011020-06202	
Checked		H. Bragandeh	Drawing No:	Work QTY. Part NO.
Approved		A. Alinaghjourn	P5000-0855	1 1
			Material: 1.2367	Min. Stock: 1
 <b>SHAHID BAHONAR COPPER INDUSTRIES CO.</b>				

Permissible Variations  
in untoleranced dimensions  
DIN ISO 2768-1 Fine